

## ***Birmingham Health, Safety & Environment Association***

Registered Charity No.: 255523

721 Hagley Road West  
Quinton, Birmingham B32 1DJ

Email: [secretary@bhsea.org.uk](mailto:secretary@bhsea.org.uk)

Website: [www.bhsea.org.uk](http://www.bhsea.org.uk)

Fax: 0121 421 3463

Tel. No. 07802 973795 (09.30 – 12.30) only

Secretary: Andrew Chappell C.Eng., MIET., Dip.E.E., CMIOSH, MCMI

# *Newsletter*

## *April 2008*

### *Welcome* to Our New Members

- Reuben Evans, Health and Safety Consultant, NFU Mutual Risk Management Services Ltd.
- Michael Donoghue, Trainee Health & Safety Manager, MITIE Property Services UK Ltd.
- Jane Antill, Managing Director, Jafco Tools Ltd.

## *Corporate Manslaughter Seminar*

*Wednesday 11<sup>th</sup> June 2008 National Motorcycle Museum*

This is the most significant Health and Safety legislation to be placed on the Statute Books for many years. It is aimed at Directors and Senior Managers in all sectors of commerce and industry, as well as the public sector organisations. This half-day event is really “unmissable” for all organisations which might place their employees, their contractors or even members of the public at risk of death at work!

A unique feature of this Seminar is that we will also be addressing the issue of other sweeping, proposed changes to sentencing under the existing Health and Safety at work etc., Act 1974. We will assess what the effect of this formidable tranche of new legislation is likely to have on management behaviour. The booking form is enclosed with this issue of your Newsletter.

## *Monthly Meeting on Monday 14<sup>th</sup> April 2008*

**C**hairman, Bob Cole of Morgan EST, welcomed 54 Members and visitors to the meeting, especially Phil Cole, AXA Insurance, Mark Lane of Bath University and Mike Balham Open University, who were all attending for the first time.

Apologies from Gerry Mulholland, Tony Thorne and Bill Parker were read out by the Secretary.

# Tackling COSHH in the Real World!

Presentation by Simon Bull, Managing Director, Castle Group

**S**imon's Company was originally set up in 1971 and, after a management buy out in 1980 has grown steadily from its core activity to design, make and sell instruments. It has now extended its range of activities to include, renting, repairs and servicing, a training academy and Consultancy.

In line with his theme of 'Simplicity', Simon started by debunking some of the common myths associated with COSHH Assessments, namely: -

- "Air sampling is difficult to do"
- "You have to understand chemistry to handle COSHH"
- "Gas detection is expensive" – not with the disposable, cheap gas detectors available.
- "COSHH Risk Assessments are too complicated" – look at the COSHH Essentials guidance on-line from the HSE!
- "As long as we use PPE, we'll be alright" – No – you need to select it with great care after making the assessment, and then look after it afterwards.

Simon then went on to describe some of the significant differences in the physical characteristics of the substances that might be inhaled: -

- **Dusts** – Particles of a solid, made by abrasion
- **Gas** – Normally airborne at room temperature
- **Vapour** – Normally liquid at room temperature
- **Fume** – An airborne solid made chemically (Not a bad smell, as by common myth)
- **Mist** – Airborne liquid droplets (Aerosols have the same physical characteristics, but are smaller)

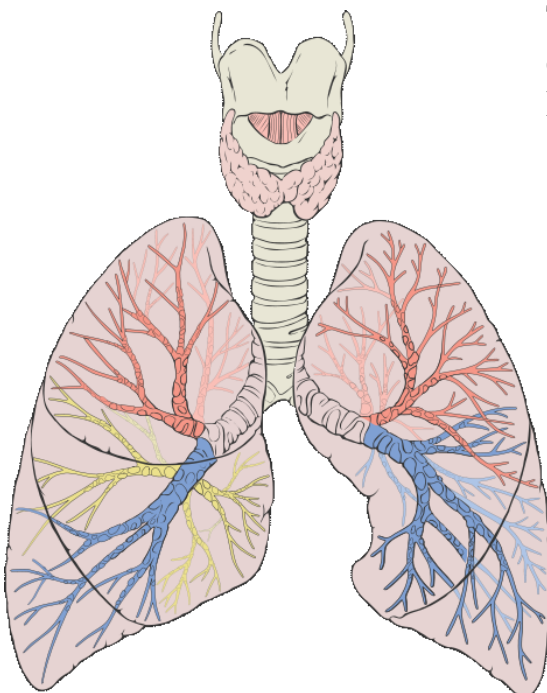

This diagram shows how dusts penetrate differently to the various parts of the Respiratory Tract: -

- Inhalable - Through Nose/Larynx  
- < 100 microns
- 
- Thoracic – Through the Bronchi  
- < 30 Microns
- 
- Respirable – To the Alveoli  
- < 8.5 Microns

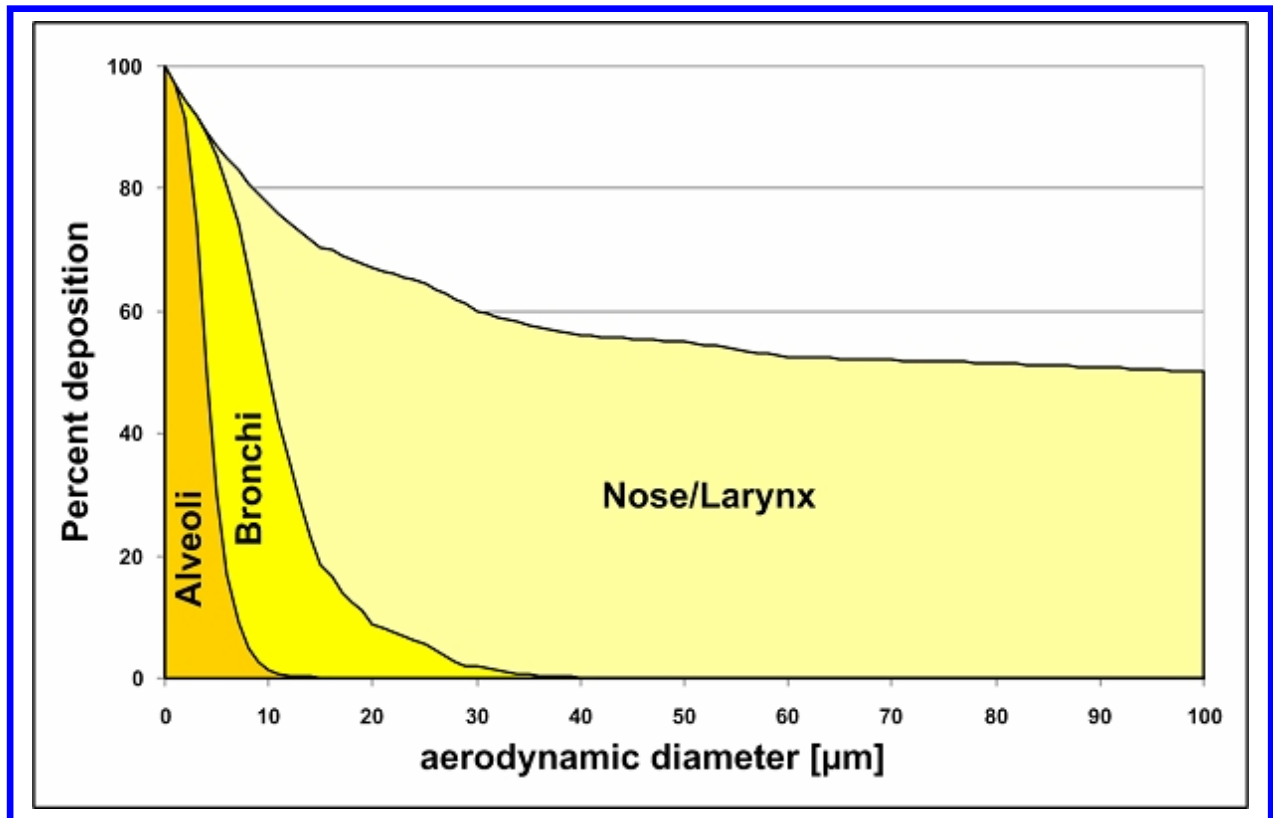

This is the graphical representation of those penetration characteristics, with respect to particle size. The amount of substance present is measured in either in Milligrams/Cubic Metre ( $\text{mg}/\text{m}^3$ ) OR Parts Per Million (PPM) and Simon gave us these comparisons to indicate the physical concentrations of the units: -

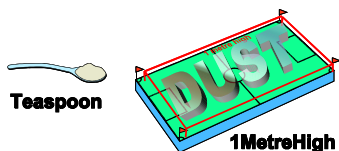

1  $\text{mg}/\text{m}^3$  is the same as 1 teaspoon full of flour spread in an airspace as large as a football pitch, 1 metre high



1 PPM is about the same as the capacity of a party balloon, in the volume of 50, three-bedroom houses. This unit is used for gases and vapours only.

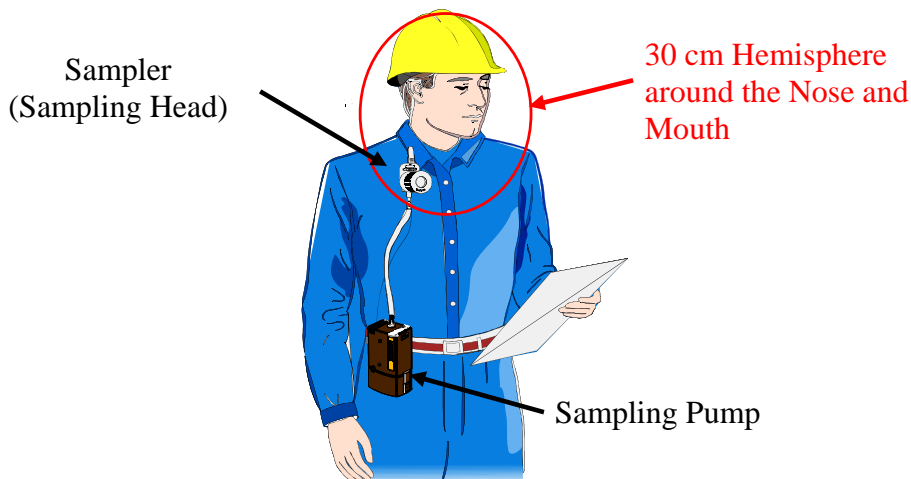

The air in the operative's breathing zone must be sampled to determine the exposure level associated with each job and this arrangement is most commonly used. At the start of the test, the pump is adjusted to pull in air at a rate of 2 litres per minute, by means of a Rotameter, shown below.

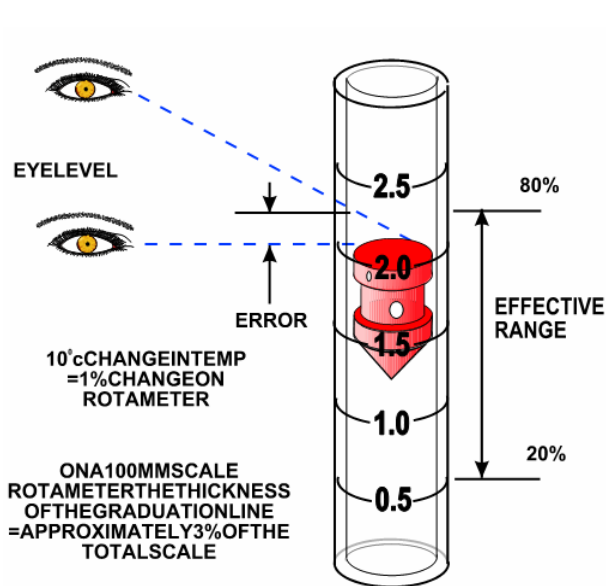

**Rotameter Calibration**

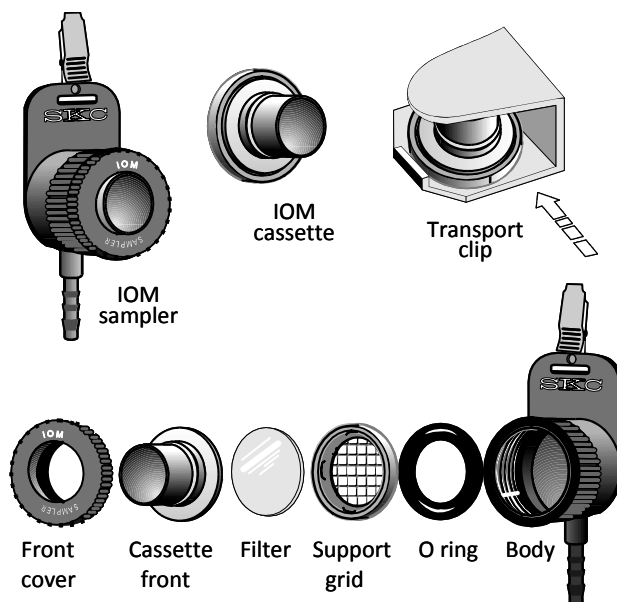

**Sampler Assembly – Inhalable Dust**

The general arrangement of the sampler head is shown above, with the Filter paper that captures the particles as they are pulled through by the pump. This filter is weighed before and after the test in a laboratory so that the weight of substance captured can be calculated.

For measurement of Respirable Dust, a Cyclone sampler head is used to separate the different sizes of particle, as only the smaller particles are required for measurement. This is usually calibrated at about 2.2 litres/minute and the paper filters are weighed in the same way as the others.

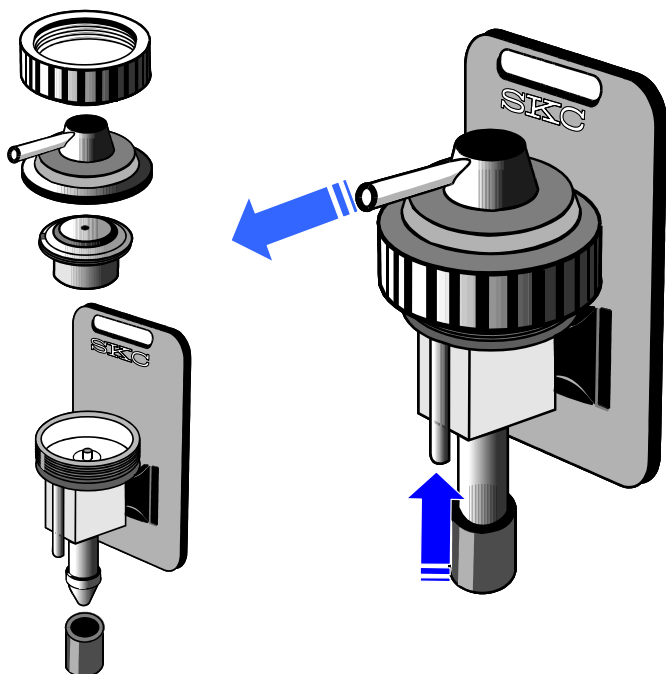

**Cyclone Sampler for Respirable Dust**

The calculation of the exposure levels is made as follows: -

We have a **TIME** for the sample period  
 We have a **FLOW RATE** from calibration

$$\text{TIME} \times \text{FLOW RATE} = \text{VOLUME}$$

(1,000 litres = 1m<sup>3</sup>)

WE have a **WEIGHT**

$$\text{WEIGHT} \text{ divided by } \text{VOLUME} = \text{CONCENTRATION}$$

$$\frac{\text{CONCENTRATION} \times \text{TIME (Hours)}}{8} = \text{TWA}$$

**TWA is what you compare to the “Work Exposure Limit” (WEL) in the EH40**

This is the Concentration averaged over 8 hours and some substances also have the concentration quoted for Short-term exposure limits of 15 minutes where there are rapid effects from exposure! WELs are NOT established as SAFE working levels but are

limits that should not be exceeded and exposures should be reduced as much as possible below them. Some substances do not have WELs but the **Occupational Health and Safety Association (OSHA) of America** may publish limits for some of these. In determining what is considered to be “safe”, Simon commented that civil law suits could be more important than what is, or is not, in EH40!

Simon went on to deal with the exposure risks for Gases and Vapours, which were, he said: -

- Toxic - involving a reaction with human tissue
- Allergic - Skin, Eyes, Anaphylaxis
- Asphyxiant - Replaces O<sub>2</sub> in the air
- Narcotic - Impaired reactions and injury
- Sensitising - Allergy, Asthma
- Anaesthetic - Dulled sensations
- Carcinogenic - Cancer Causing

Again, as with dust, sampling exposure levels is a crucial part of making a COSHH Assessment in order to ensure compliance. The sampling train is similar to the arrangement for dust, except that the filter is replaced with a detector tube for the specific gas/vapour to be monitored. Simon demonstrated, with a CO<sub>2</sub> Detector tube, that the level in the BMI Main Hall was 1,500 PPM! The pump needs to be calibrated for specific tests and the flow rate can be varied considerable by means of several calibrating devices. With low flow rates that could be needed for some tests, the Bubble Film Calibrator or Automatic Calibrators were the preferred options.

Gas Detector systems, however, were needed to protect persons from harm by exposure to Toxic or Asphyxiant gases and/or vapours. Simon said that there was a wide choice available, all of which were comparable in performance and cost. He displayed a “4 – Gas sample that could detect the standard gases O<sub>2</sub>, H<sub>2</sub>S, CO and Flammable (%LEL). He added that the Flammable element did not work in some gases, where there might be a concentration outside the Lower and Upper Explosion Levels. Other available choices were: -

- Volatile Organic compounds (VOCs) – a Photo-Ionisation Detector (PID) is required for this.
- Carbon Dioxide – requiring an Infra-Red Sensor. Simon added that the user might be more concerned about low O<sub>2</sub> levels than the asphyxiant effect of CO<sub>2</sub>!
- And many more!

In summary, Simon went on to say that the important things that a good COSHH Assessment should address were: -

- It needs to be done BEFORE the work is carried out. This requires good inventory control to ensure that hazardous substances CANNOT be procured by trades people, supervisors, or even Managers, before they have been assessed and the purchase sanctioned.
- The nature of the hazard and health effects are known

- The level, type and duration of any exposure is measured and compared to the WEL
- Identify the high risk activities and how they are carried out
- Determine what preventative and control measures are already carried out and whether any additional ones are needed
- Identify whether substances can combine to produce other risks
- Take account of Biological Agents, particularly as these are not 'purchased' and may go un-noticed.
- AND Review when necessary!

Simon went on to say it is important to keep a sense of perspective about what needs monitoring and when it should be done. He quoted examples of the early formulae for Tippex with a minute amount of 1.1.1 Trichloroethane and commented that, whereas for small quantities used by typists it was a low risk, in the manufacturer's and packaging companies it could be a very high risk. He added that the same could be said of 'users' replenishing sealed toner systems on photocopiers, compared to the manufacturing plants producing the toner cartridges.

A different situation existed in a sawmill, he said, which would need regular monitoring of wood dust to make sure that the extractor systems were operated correctly and were also maintained in good order. Equally, where complex chemicals were in use, the assessor might need to consult Manufacturers, the Internet and COSHH Essentials on line! Exposure levels on Asbestos work and Clearance Certificates were other obvious examples of the need for accurate monitoring, and Simon strongly recommended that this particular substance should be left strictly to the experts! Work in Confined Spaces was also another range of work needing careful assessment, design of control measures and equipment, in addition to continuous detection monitoring for toxic atmospheres.

### *Members' Questions*

**Bob Cole** asked what standards were applicable to sampling training? Simon replied that it was difficult so define 'competence' other than to say that Castle Training gave an ability to do it competently and it was designed for persons with no previous knowledge of testing. He added that Castle could provide courses for up to 6 persons.

**Mike Balham** commented that it was important to adhere to the hierarchy of control and THEN carry out monitoring. **Philip Lane of Greggs of the Midlands** added his bakery company monitored the Flour Dust levels every two years, to ensure that the control measures were operating effectively and that it was a simple test procedure.

**Dawn Phillips of Wolverhampton City Council** asked if there was any calibration system suitable for disposable detectors. Simon replied calibration was not required as they performed an alert function only and were not used in COSHH assessment. Dawn went

on to ask if detector tubes should be kept in a fridge and Simon responded by saying that some do and that the charcoal tubes had the most sensitive storage requirements.

As there were no more questions, the Chairman closed the meeting by thanking Simon for his very valuable presentation and asked the members to show their appreciation.

## *WWT Roofers SHAD*

For the Construction Section Members only, we have included copies of the publicity leaflets and booking form for this event at Briggs Amasco in Cradley Heath on 26<sup>th</sup> June 2008.

There will be the usual range of practical demonstrations with one or two surprise packages for those who are lucky enough to book first!

## *HSE reviews its stance on Suspension Trauma!*

Some of you might remember the warnings I sent out about “Harness Fatality Risks”, in January last year. This warning concerned the perceived physical reaction that could be experienced by fall victims hanging in harnesses too long whilst they waited to be rescued. The guidance at the time had concluded that special First Aid measures were needed to treat the build up of toxins in the victim’s blood due to the restriction of circulation by the harness!

Thankfully, **Mike Webb of Old House Holdings** did remember this warning when a colleague informed him of a recent stakeholder meeting on the subject at the HS Laboratory in Buxton last month.

Apparently the HSE, in response to questions from the Construction Industry about the original alert, commissioned fresh research into the risk of suspension trauma. Their medical experts, industry stakeholders and the Ambulance Services have now revised the original guidance on this topic.

There are still some unanswered questions on this condition but we understand that fresh guidance will be issued in due course, which will change the recommendations on first aid treatment.

## *Date of the next Meeting*

2.00 pm on Monday 19<sup>th</sup> May 2008  
at the Birmingham Medical Institute

### **“Update on the new Noise Regulations”**

*Steve McCrorie, Sypol Ltd.*

*With the end of the transitional period for the leisure industries, it is appropriate to review the effect of the significant changes introduced by the Control of Noise at Work Regulations 2005.*

*Steve McCrorie delivers the Sypol 3-day course on the Noise Regulations and is well placed to tell us about the impact of its lower action levels. More importantly, he can give us a wealth of guidance on effective, practical methods of controlling the risk so that it is never allowed to harm people's hearing in the first place!*

*As usual, there will be a Buffet Lunch at 1.15.pm  
Be there early to avoid disappointment!*